

The Unico System®



INSTALLATION MANUAL FOR 'M' SERIES SLIDE-IN HEATING COIL

General

The information on the following pages is to help the installer save time, provide the best possible installation and insure continuous trouble-free operation.

The Unico System Hot Water Coil is designed for use with the Unico 'M' series air handlers and the Unico air distribution system. The coil is designed to be used with virtually any source of hot water including gas, oil, or electric boilers; wood-fired boilers; solar heating systems; or domestic hot water "Combo" systems.

Scope

These instructions apply to the Unico "M" Series slide-in heating coils. Refer to *Bulletin 20-20.4* for performance tables for the HW2430 and HW3660. Refer to *Bulletin 30-10* for the HW1218 performance tables and pressure drops.

Refer to the boiler or hot water heater manufacturer's instructions for piping and pump layout and installation.

Equipment

Unico manufactures three size hot water heating coils that are designed to slide into a Unico M Series Heating Module or the single piece M1218 fan-coil unit. Model HW1218 fits the M1218 unit, model HW2430 fits into the MH2430 and MV2430 cabinets and model HW3660 fits into the MH3660 and MV3660 cabinets. All necessary mounting brackets are included. The Heating Modules are sold separately or including the coil with the MH modules.

NOTICE TO INSTALLER AND EQUIPMENT OWNER: RETAIN THIS MANUAL AT THE JOB.

FULL BUILDING INSULATION IS ESSENTIAL FOR THE MOST ECONOMICAL OPERATION

General Precautions and Safety Tips

Do not attempt to install or startup unit without first reading and understanding the appropriate sections in this manual.

Installation should be in accordance with all local codes and regulations and with the applicable National Fire Protection Association (NFPA) standards. In case of conflict, local codes take precedence.

All electrical wiring should be in accordance with the latest edition of the National Electrical Code and all local codes and regulations. The unit is safety certified to UL 1995 and listed with ETL.

Always install a secondary drain pan when water could cause damage.

Unpacking

All coils are inspected prior to shipping and are carefully packaged in individual cartons. Inspect all cartons prior to unpacking. Notify carrier of any damage.

Open each carton to remove the coils. Inspect for visible signs of concealed damage and notify carrier of any such damage. All materials are sold FOB Factory and it is the responsibility of the consignee to file any claims with the delivering carrier for materials received in damaged condition.

Installation

The coil may be inserted into the Heat Module cabinet before or after the module is installed. Refer to *Bulletin 30-20* for the air handler installation instructions.

Use the following steps to insert the coil:

1. Remove the access plate from the side of the Heat Module.
2. Cut the insulation away, using the opening as template. Retain insulation for Step 5.
3. Slide the coil in as far as possible so return bends press into the insulation on the inside of the module
CERTIFIED TO UL STD 1995
CAN/CSA STD C22.2 NO. 236

cabinet. Coil must be fully inserted to assure that the cover plate can be installed after coil is piped.

4. Pipe coil following instructions in “Piping” section that follows below. Be sure system is filled with water, bled of air and checked for leaks.
5. The insulation from Step 2 is to be used to insulate the copper tubes of the coil. Notch the insulation for the Water IN and Water OUT lines and position it in the original opening over the coil tubing.
6. Install the coil cover plate supplied with the coil over the insulation. Maneuver the plate so notches fit around the water lines. Screw the cover plate in place using screws removed from the access plate.
7. Caulk around the Water IN and OUT lines to assure no air leakage. Also check around the edges of the cover plate for air leaks with blower operating. Caulk edges or seal with UL181A-P aluminum foil tape.

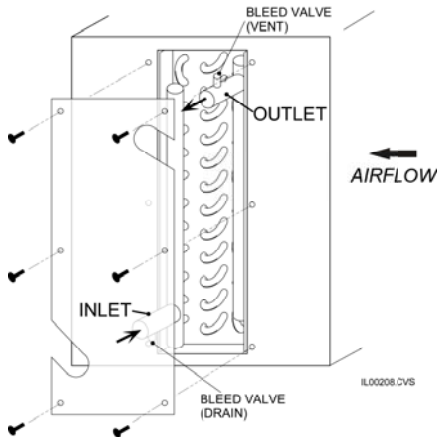

Figure 1. Hot Water Coil with Cover Plate

For horizontal applications the heating module will be installed upstream of the cooling module. For this configuration the hook-flange provided (loose) with the MH unit must be attached to the cooling module (see Figure 2). In hydronic heating only applications, use the hook-flange on the blower module to attach the MH unit.

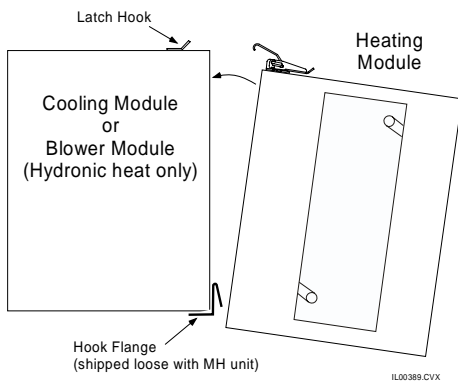

Figure 2. Hook-flange Location

Piping

All piping must be in accordance with all local codes and ordinances. Pipe sizing and pump selection must be designed to match, allowing for the pressure loss in the coil and all other fittings. Refer to ASHRAE Fundamentals Handbook for design guidelines.

The *Unico System* Hot Water Coil can be piped as a single zone or in a multi-zone system. In either system, the water flow may either be continuous or intermittent.

In a continuous flow system, the fan is simply cycled on and off by the thermostat. In an intermittent flow system, water is circulated through the coil only when heat is required. The fan can run continuous or at the same time as the water. The intermittent system will use either pump on/off control, or mixing or isolation valves to control the water flow.

An optional aquastat can be installed with the intermittent system to prevent blowing of cold air by delaying the fan until the water in the coil is hot.

M2430, and M3660 connections are 7/8-inch (22 mm) sweat connections. M1218 connections are 5/8 inch (15.8 mm). Solder or braze the water connections, and then fill the system. Bleed the air from the coil by backing off the screw inside the bleed valve for venting. Water pressure drops through the coil can be found in Bulletin 20-20.4 for the M2430 and M3660 and 20-18 for the M1218.

A secondary drain pan must be used under unit if installed where a water leak could cause damage. Unico has available secondary drain pans for horizontal applications. For vertical unit applications it will be necessary to fabricate a drain pan which should provide at least 1/2-inch (12.7mm) clearance around all sides at the bottom.

For vertical upflow arrangements where the air enters the bottom of the unit, use the vertical plenum (MV) module for the M2430 and M3660. Coil installation is identical to the MH installation instructions and shown in Figure 1. Detailed specifications for the MV unit are available in Bulletin 20-20.5.

For vertical downflow (counterflow) installations it is difficult to provide a secondary drain pan because of the blower discharge at the bottom. If a secondary drain pan is needed it must be fabricated with an opening for the blower discharge and still provide a sealed drain pan.

Freeze Protection

If unit is in an unconditioned space below freezing, care must be taken not to freeze the water in the coil. There are two methods of freeze protection. The easiest is continuously or intermittently circulate the water. Another method is to use a glycol-water antifreeze solution with a



freezing point below the coldest temperature expected. Using antifreeze, though, can reduce the output of the coil.

If the coil is not in use during the cold temperatures, drain the system then flush with a glycol solution.

Wiring

WARNING!
DISCONNECT ELECTRICAL SUPPLY BEFORE WIRING UNIT TO PREVENT INJURY OR DEATH FROM ELECTRICAL SHOCK.

All electrical wiring must comply with all local codes and ordinances.

For most heat-cool thermostats, it is necessary to install a separate (not included) double-pole double-throw (DPDT) relay as shown in Figure 3. This provides a set of open contacts that serve as a switch to energize a boiler, a solenoid valve, or a pump. At the same time, the relay will energize the indoor blower. This control diagram will still allow for constant air circulation; however, the water flow would need to be stopped to prevent overheating the conditioned space. Using the DPDT relay allows you to start the pump or open a valve when the thermostat calls for heat.

In certain situations an aquastat is not used. For this setup, connect the bypass wire as shown in Figure 3. This configuration will energize the fan at the same time as the boiler.

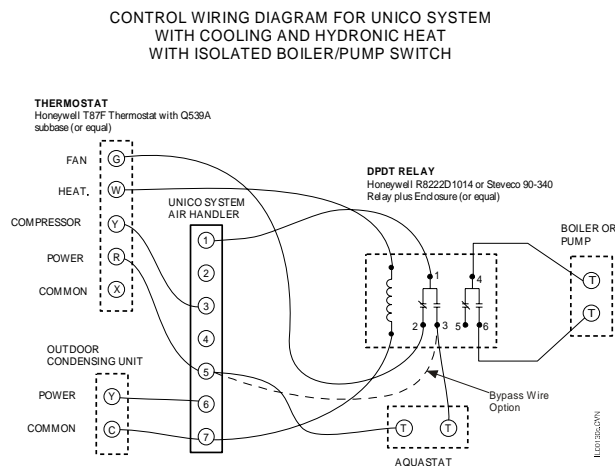

Figure 3. Wiring Diagram for Cooling and Boiler Heating Applications with DPDT Relay

If constant circulation is not needed, the blower can be energized without the DPDT relay provided the thermostat will energize the blower ('G' circuit) in heat mode. Most electric furnace subbase thermostats will provide this feature. A wiring diagram of this setup is shown in Figure 4.

Note: A normal heating-cooling thermostat may not close the "G" circuit on heating.

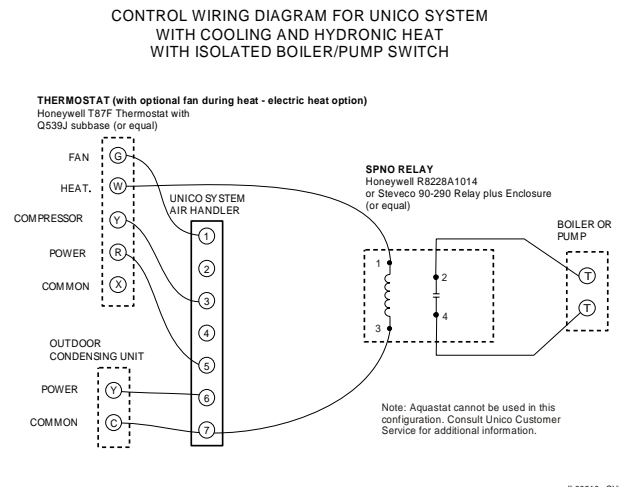

Figure 4. Wiring Diagram for Cooling and Boiler Heating Applications with SPNO Relay

The Unico Advanced Control Board is another option for hot water heating systems. The advanced control board is adaptable to just about every practical heating application; refer to Bulletin 30-38.

Startup

Sequence of Operation. The sequence of operation greatly depends on the options installed and type of control thermostat used. Most thermostats have a fan AUTO-ON switch. When the fan switch is set to ON, the "G" circuit is closed and the blower relay is energized. The indoor blower on the M1218 starts after about a 20-second delay while the "M" series blowers will start when the blower relay is energized.

The following paragraphs describe the sequence of operation when the fan is set to AUTO. If the fan switch is set to ON, the sequence is the same except the "G" circuit is always closed and the indoor fan is always operating. Refer to Bulletins 30-10 and 30-20 for wiring diagrams of the M1218 and "M" series modular air handlers.

Heating Cycle. When the thermostat calls for heating, only the "W" circuit is closed for most thermostats, sending a 24 V signal to a DPDT relay (separate from the air handler control box). This external relay will close an isolated switch that starts the boiler or pump. Then after the optional aquastat is satisfied the indoor blower will start. Suggested placement for the aquastat is on the water inlet pipe as close to the coil as practical.

When the thermostat is satisfied, the 24 V signals are cut and the pump and blower will stop. The indoor blower for the M1218 continues to operate for about 30 seconds, then stops. The system is now off.

Piping and Thermosiphoning Effect

Thermosiphoning is the natural, convective movement of air or water due to difference in temperature. In a hot water system, if the water heater is installed lower than the coil, the hot water will not stay in the water heater when the pump is turned off. The following piping schematic shows how thermosiphoning can be prevented:

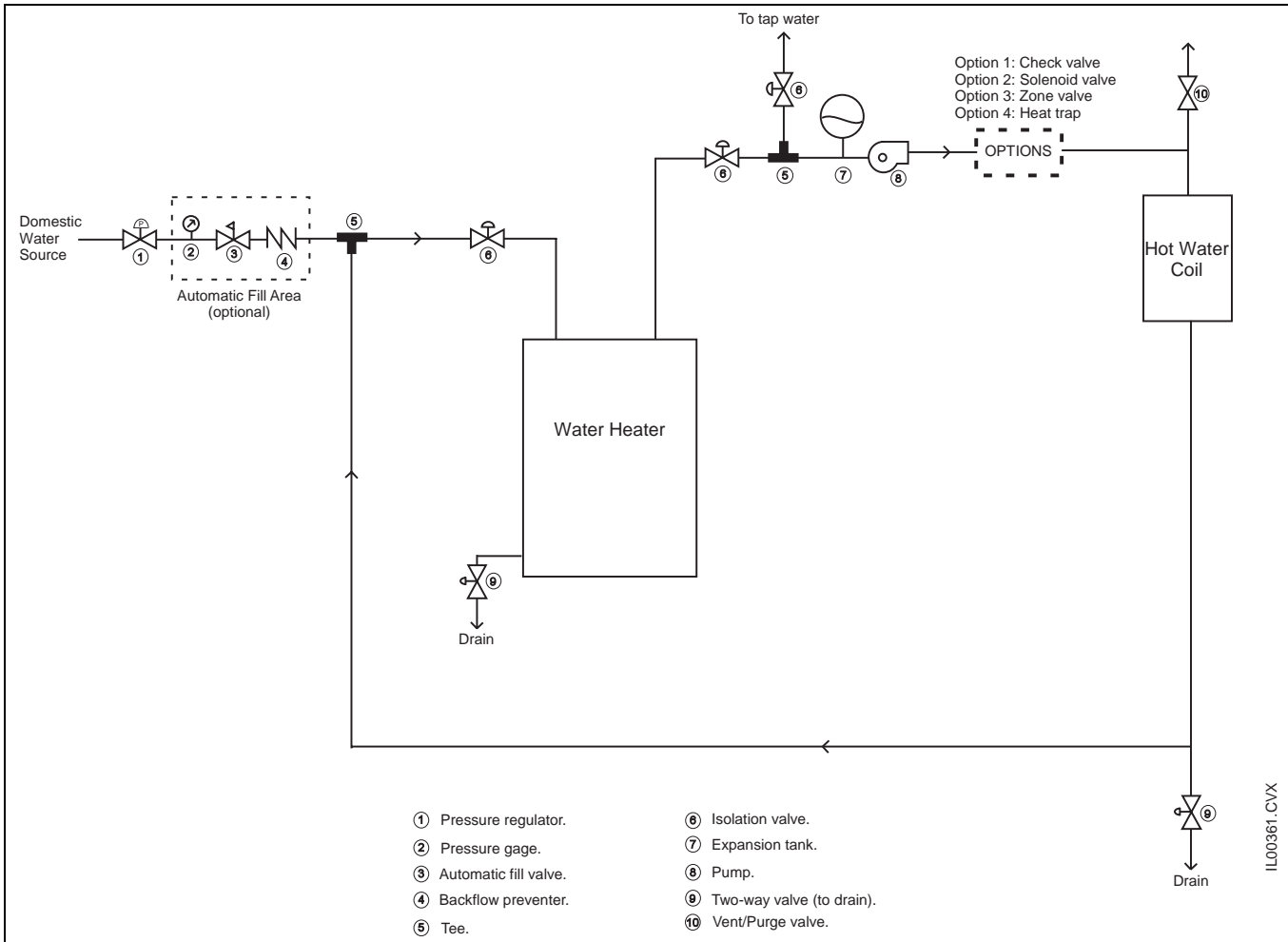

OPTION 1: Install a **check valve** at the supply of the coil, downstream of the pump.

OPTION 2: Install a **solenoid valve** at the supply of the coil, downstream of the pump.

OPTION 3: Install a **zone valve** at the supply of the coil, downstream of the pump.

OPTION 4: Add a **heat trap** at the supply of the coil, downstream of the pump.

If the coil is installed lower than the water heater, there is no need for the options mentioned above.

Single Return System Configuration

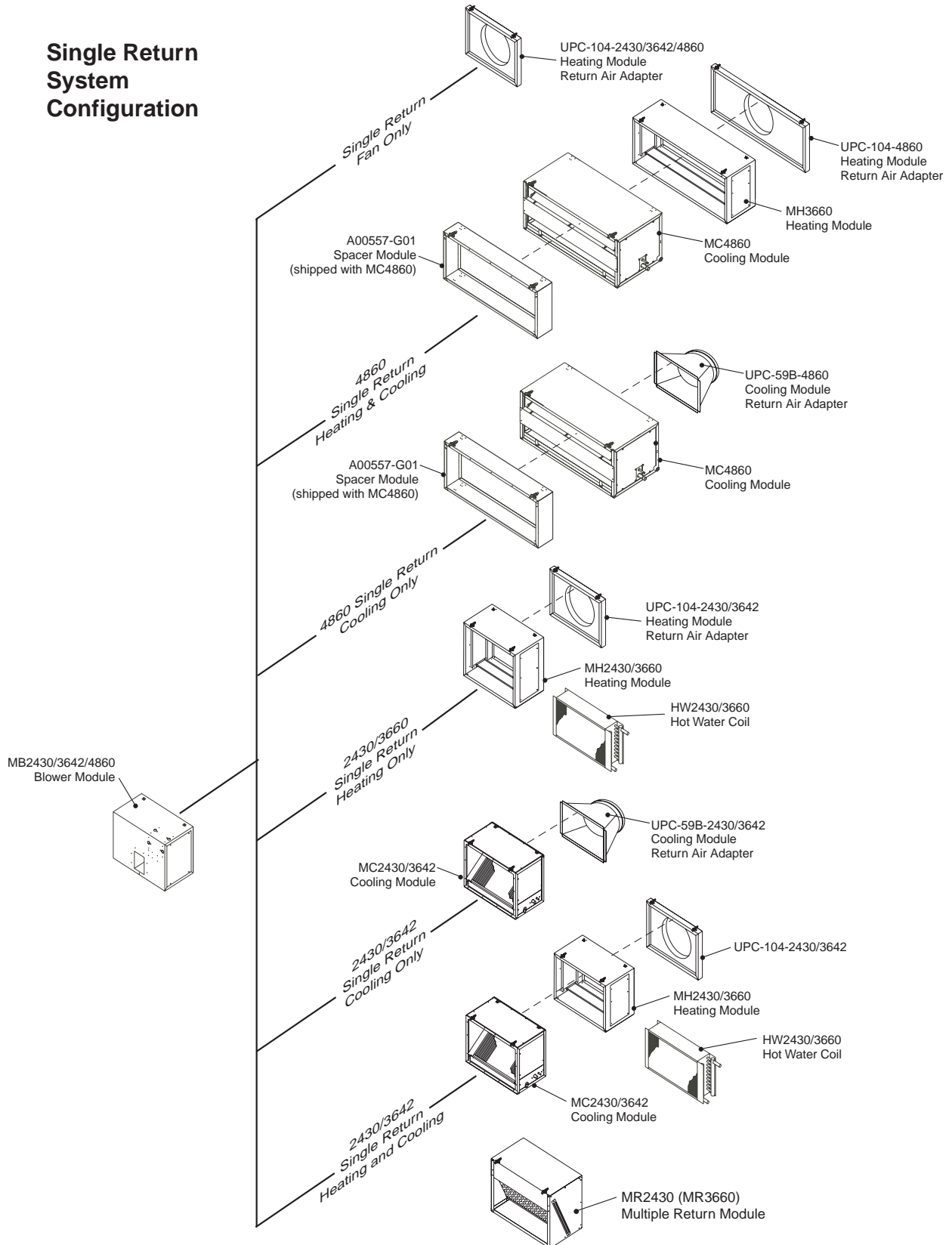

If using multiple returns replace single return adapter with the correct MRxxxx module, where xxxx stands for unit size.

IL00316.CNV

UNICO SYSTEM Vertical Installation

*A00556-G01 and A00557-G01 are shipped with the MV2430 and MV3642, respectively. The MV4860 is not shipped with an A00557-G01. The MC4860 is shipped with an A00557-G01.

