

Vertical Plenum (MV) Module

General

All Unico System modular air handlers are shipped from the factory configured for horizontal airflow but may be also configured for vertical up-flow with the addition of a vertical conversion kit. Most applications designed for vertical configuration use a base plenum to elevate the unit for proper condensate drainage. The Unico System MV module eliminates the need for the installer to build a base.

Features and Scope

The MV module features a built in secondary drain pan with a 3/4" PVC socket connection, pleated filter, and place for an optional hot water coil. The MV module features access panels on both sides so that the heating coil may be inserted from either side.

The module may be connected to a heating module return adapter, UPC-104, or operate as a free or "wild" return. If the air is filtered elsewhere, such as at a filter grille, then the central filter in the MV may be removed.

The MV2430 matches the MC2430 cooling module in addition to the older MC2436 series; the MV3642



Figure 1. MV Module shown without hot water coil (hot water coil is sold separately).

matches the MC3642 and the older MC4260; and the MV4860 matches the MC4860 cooling module.

Cabinet Construction

The cabinet is constructed of 22 gauge galvanized steel. It has a removable access panel to insert a hot water coil. The cabinet is fully lined with closed cell insulation. The cabinet does not contain fiberglass insulation. Easy snap latches are included for quick field assembly with the mating modules.

Optional Hot Water Coil

Refer to Bulletin 20-20.4, "M" Series Heating Module, for hot water coil specifications and performance. The following table indicates the size of hot water coil to be used.

Table 1. Hot water coil

Model	Hot Water Coil Model	Maximum Capacity, Btu/hr (kW)
MV2430	HW-2430	62,400 (18.3)
MV3642 MV4860	HW-3660	120,000 (35.2)

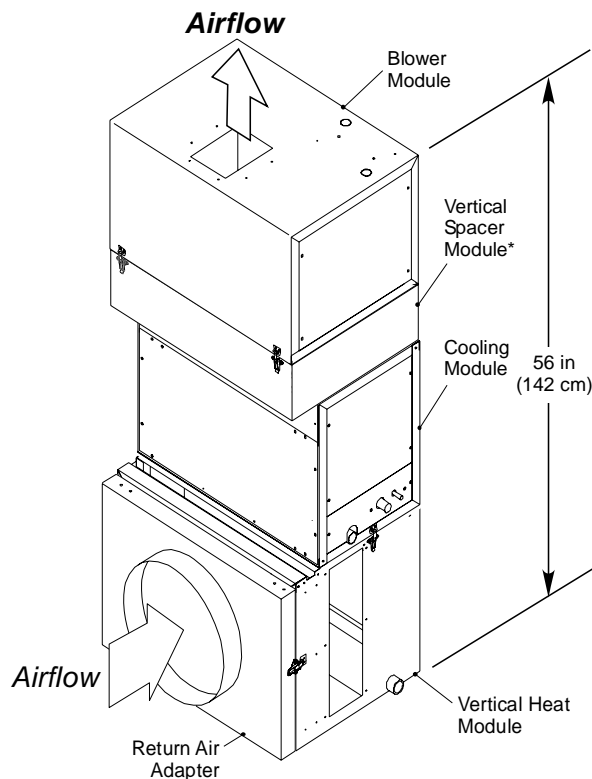

Typical Vertical Installation with Vertical Heat Module

Specifications

Filter Type: Pleated, 1 inch (25 mm)

Initial Filter Resistance:

- 0.22 inches water at 375 FPM
(54 Pa at 1.9 m/s)
- 0.40 inches water at 500 FPM
(100 Pa at 2.5 m/s)

Table 2. Filter Size and Maximum Airflow

Models	Filter (Qty) and Size		Maximum Airflow, CFM (L/s)
	inches	mm	
2430	(1) 18 x 25	(1) 457 x 635	600 (282)
3642	(1) 20 x 18	(1) 508 x 457	1250 (590)
4860	(1) 18 x 18	(1) 457 x 457	

Dimensions

Model	MV2430	MV3642	MV4860
Dimension, inches (mm)			
A	25 (625)	38 (950)	38 (950)
B	23 (584)	36 (900)	32.11(892)
C	6.88 (172)	6.88 (172)	9.35 (238)
D	17.5 (438)	17.5 (438)	23 (584)
E	1.0 (25)	1.0 (25)	4.0 (102)

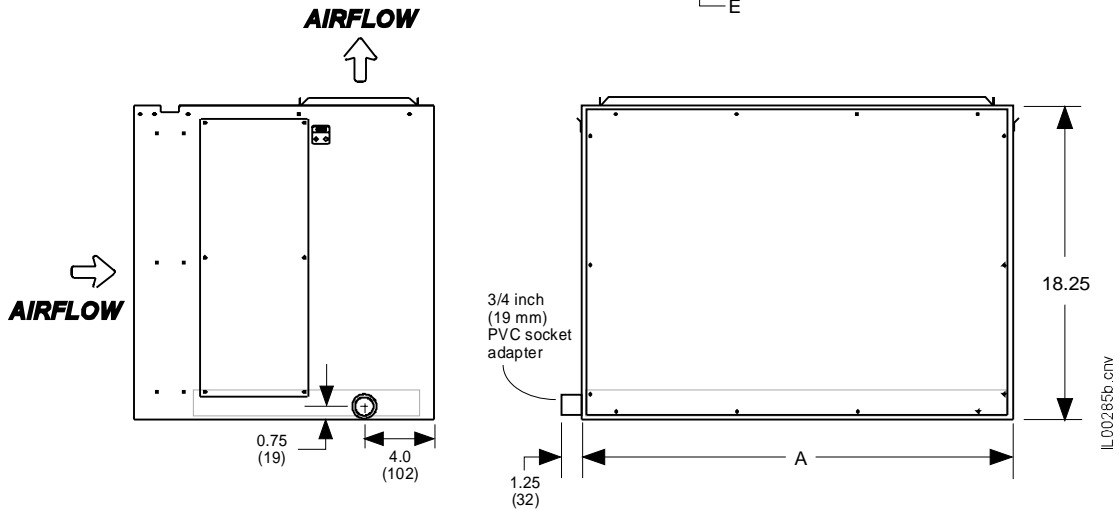
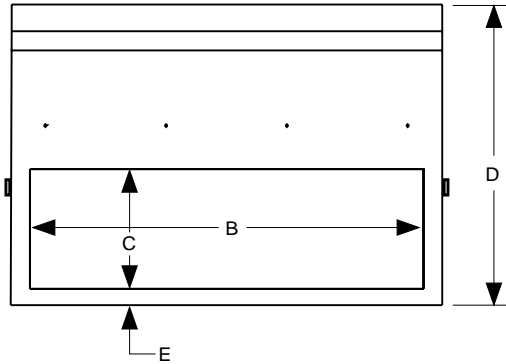

Parts List

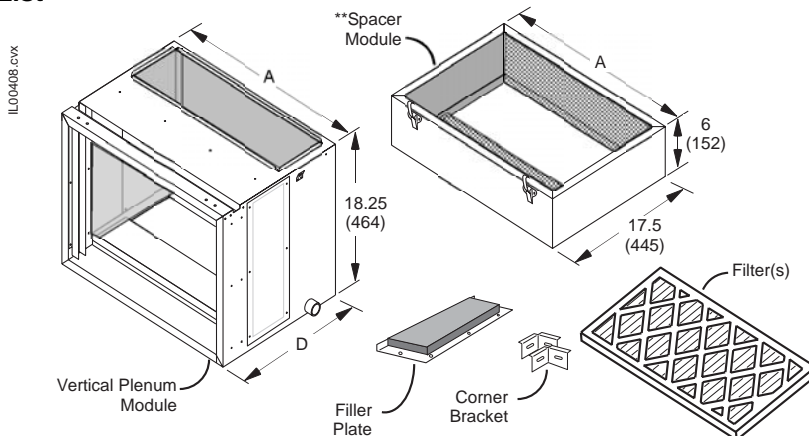

Vertical Plenum Kit

- Kit includes
- Vertical Plenum Module
 - Vertical **Spacer Module
 - Pleated Filter(s)
 - 1 Insulated filler plate
 - 2 Corner Brackets
 - Screws
 - Latches
 - Latch Keepers
 - Insulation Strips

- Features:
- Everything needed for converting horizontal to vertical system is included
 - Easy to install

**Spacer Module is not required or included with the MV4860