

M SERIES COOLING MODULE REFRIGERANT COILS for R-22, R-407C, R-410A

Packing List

Package includes:

- 1- Cooling Module
- 2- Latches
- 2- Latch Keepers
- 8- Screws for latches and keepers (MC4860 has 12)
- 1- Defrost relay (Heat pump only)
- 1- Thermostatic expansion Valve (R-22 or R-410A)
- 1- Liquid Line, 3/8-inch (9.5-mm) OD
- 1- Spacer Module (MC4860 only)

Features

- Unobstructed face area for better heat transfer and airflow
- Easily accessible and replaceable TX Valve
- Compatible with R-22/407C/410A refrigerants
- Standard *Unico System* 'latch' system

Applications

Unico System designed and built evaporator coil modules can be easily installed with the matching *Unico System* blower modules. See coil/blower match-up table below. The evaporator can be matched to most types of remote condensing units or heat pumps. See ARI directory or call factory for capacities and ratings.

Typical Application

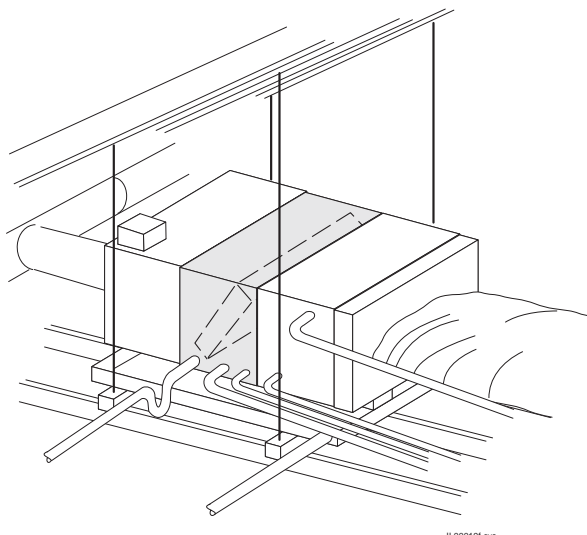

Horizontal installation with *Unico System* Heating Module and Blower Module



Figure 1. Refrigerant Cooling Module with cut-away showing coil

Table 1. Matching Blower Modules

Evaporator Coil		Matching Blower
Cooling Only	Heat Pump	
MC2430C	MC2430H	MB2430L
MC3642C	MC3642H	MB3642L
MC4860C	MC4860H	MB4860L

Construction

The cabinet is constructed of 22 gauge (0.030-in, 0.762-mm) galvanized steel with removable access panels on both sides for ease of service. The cabinet is fully lined with closed cell insulation. The cabinet does not contain fiberglass insulation. Easy snap latches are included for quick field assembly.

Unico designed coils are constructed of evenly spaced aluminum fins mechanically bonded to copper tubes. The tubes are 3/8" (9 mm) diameter. Full fin collars provide the greatest tube-fin contact for excellent heat transfer. All coils are slanted, except the MC4860C or H model, which feature an 'A' coil to provide the maximum amount of heat transfer surface.

Certified to UL Standard 1995
Conforms to CAN/CSA Standard C22.2 NO. 236



Unico products comply with the European regulations that guarantee the safety of the product.

The coil is pressure tested and then factory leak tested. The drain pan is constructed of stainless steel for maximum corrosion protection with a 3/4" (19 mm) FPT drain connection. All refrigerant lines are sweat connections extending on the outside of the cabinet.

Controls

All evaporators are supplied with an expansion valve and anti-frost switch. The heat pump coil includes a TXV with internal check valve for proper operation in the heating cycle. All expansion valves feature mechanical threads (Chatleff type) connections for easy installation. All cooling-only valves include an inlet strainer. Also, for heat pump applications, a 24-volt relay switch that bypasses the anti-frost switch during the heating mode. The switch is packed loose inside the module for field installation in the space provided in the control box.

Install the valve as shown in Figure 2. Use the following steps when installing:

1. Remove plastic caps to external equalizer line and distributor inlet.
2. Connect valve to distributor and tighten nut, use new Teflon seal.
3. Connect external equalizer line and tighten flare nut.
4. Connect liquid line to the inlet of the valve using new Teflon seal. Make sure the nut is tight. See Table 2 for liquid line part numbers.
5. After all lines have been connected, pressure check the connections by charging the system with 150 psig of dry nitrogen and check for leaks at all connections.

Locate the bulb at the 3 O'clock position on a horizontal straight section of the 7/8" (22 mm) suction line (see Figure 2). Attach the bulb to the tubing with the two straps that are provided. For satisfactory expansion valve control, good thermal contact between the bulb and the suction line is essential. Insulate the bulb with cork tape to ensure proper valve operation (2430/3642). Always use new Teflon seals when installing or replacing the TXV (Unico Part No. A00809-001).

Table 2. Liquid Line Part Numbers.

Coil Type	Unico Coil Model No.	Liquid Line Part No.
AC	MC4860C	A01044-001
	MC3642C	A01023-001
	MC2430C	A01023-001
HP	MC4860H	A01045-001
	MC3642H	A01024-001
	MC2430H	A01024-001

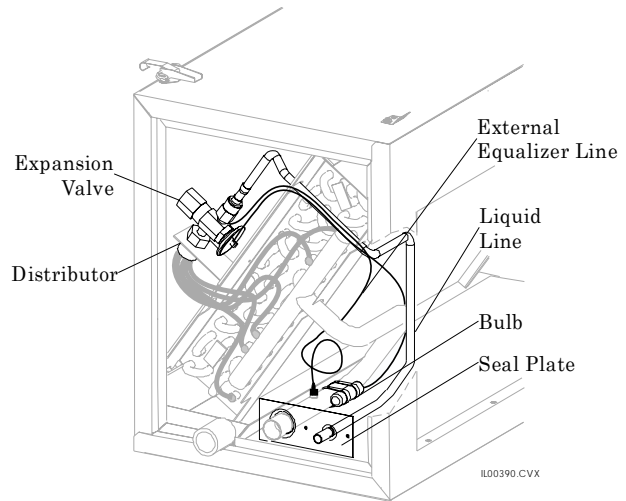

(a) 2430/3642 Expansion Valve Installation

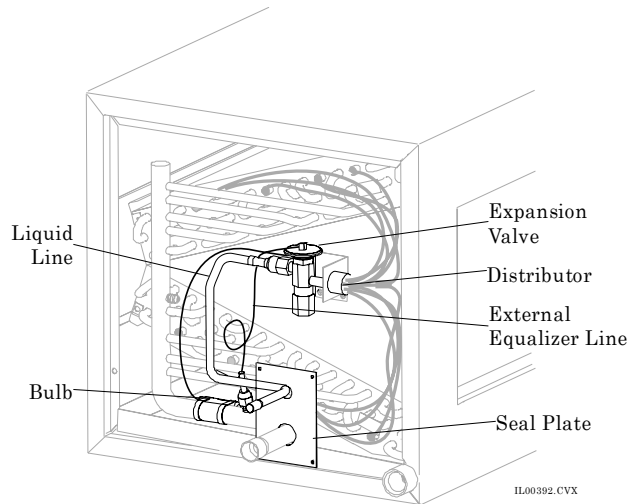

(b) 4860 Expansion Valve Installation

Figure 2. Expansion Valve Installation

Examples

Example 1. Find the total sensible heat capacity of a 2.5 Ton (8.8 kW) condenser matched to a 2430 system with indoor temperature of 80°F (27°C) dry bulb / 66°F (19°C) wet bulb.

Solution: From graph on page 5

First, determine the total heat capacity, which is defined as the sum of the sensible heat and latent heat. Sensible heat is the energy due to temperature change, whereas latent heat is the energy caused by phase change. In other words, latent heat is associated with the amount of moisture removed from the air and sensible heat is associated with the air temperature drop.

To find the total heat, trace a vertical line from the 66°F (19°C) position until it crosses the 2.5 ton (8.8 kW) line. At this point where a horizontal line intersects the vertical line is your Total Capacity in BTU/hr, which is 27,000 BTU/hr.

$$\text{Total Heat} = 27,000 \text{ BTU/hr (7.9 kW)}$$

Next, determine the sensible heat capacity using the Sensible Ratio (SHR) and the total heat capacity from above.

The Sensible Heat Ratio (SHR) is defined as the ratio of the Sensible Heat Capacity to the amount of Total Heat Capacity, where:

$$\text{SHR} = \frac{\text{Sensible Heat Capacity}}{\text{Total Heat Capacity}}$$

where,

$$\text{TotalHeat} = \text{Sensible Heat} + \text{Latent Heat}$$

To determine the sensible heat ratio, find where the wet bulb temperature crosses the selected condensing unit line. There are a series of solid lined curves numbered 1.0 to 0.45. The Sensible Heat Ratio is 0.61

$$\text{Sensible Heat Ratio} = 0.61$$

To determine the sensible heat capacity, take the Total Heat, 27,000 BTU/hr, and multiply it by the Sensible Heat Ratio, 0.61.

$$\text{Sensible Heat Capacity} = 16,470 \text{ BTU/hr (4.8 kW)}$$

Subtracting this from the Total Heat Capacity gives the amount of Latent Heat.

$$\text{Latent Heat Capacity} = 10,530 \text{ BTU/hr (3.1 kW)}$$

Example 2. Find the outlet temperature of a Unico System Heat Pump at 30°F (-1°C) at 200 CFM (27 L/s) per nominal ton (kW).

Solution: From the graph on page 8.

At the point where 30°F (-1°C) crosses the 200 CFM (27 L/s) per nominal ton (kW) line, trace a line until it crosses the “Outlet Air Temperature” on the vertical axis.

$$\text{Outlet Air Temperature} = 107^\circ\text{F (42}^\circ\text{C)}$$

MC2430x and MC3642x Specifications

Type of System		Cooling Only		Heat Pump	
Model No.		MC2430C	MC3642C	MC2430H	MC3642H
Compatible Condenser Size, Ton (kW)		2–2.5 (7–8.8)	3–3.5 (10–12.3)	2–2.5 (7–8.8)	3–3.5 (10–12.3)
Evaporator Coil	Net Face Area, ft ² (m ²)	2.13 (0.20)	3.48 (0.32)	2.13 (0.20)	3.48 (0.32)
	Tube diameter, in. (mm)	3/8 (9.5)			
	Number of rows	4		6	
	Fins per inch (m)	14 (551)		15.5 (610)	
	Suction line O.D., in. (mm)	7/8 (22.2)			
	Fin Type	lanced		corrugated	
	Number of Circuits	5	6	6	6
	Valve, R-22/R-407C, Part No.	A00805-002	A00805-004	A00808-002	A00808-004
	Valve, R-410A, Part No.	A00805-013	A00805-014	A00808-013	A00808-014
Liquid line, in. (mm) OD	3/8 (9.5)				
Design Pressure, psig (kPa)		500 (3447)			
Condensate Connection, in. (mm) FPT		3/4 (19)			
Refrigerant		R-22, R-407C, R-410A			
Coil Shipping Weight, lb. (kg)		60 (28)	78 (35)	60 (28)	78 (35)
Expansion Device*		TXV		TXV with internal Check Valve	
Dimensions	A	25 (635)	38 (965)	25 (635)	38 (965)
	B	23 (584)	36 (914)	23 (584)	36 (914)
	C	20 (508)	33 (838)	20 (508)	33 (838)

* TXV shipped loose

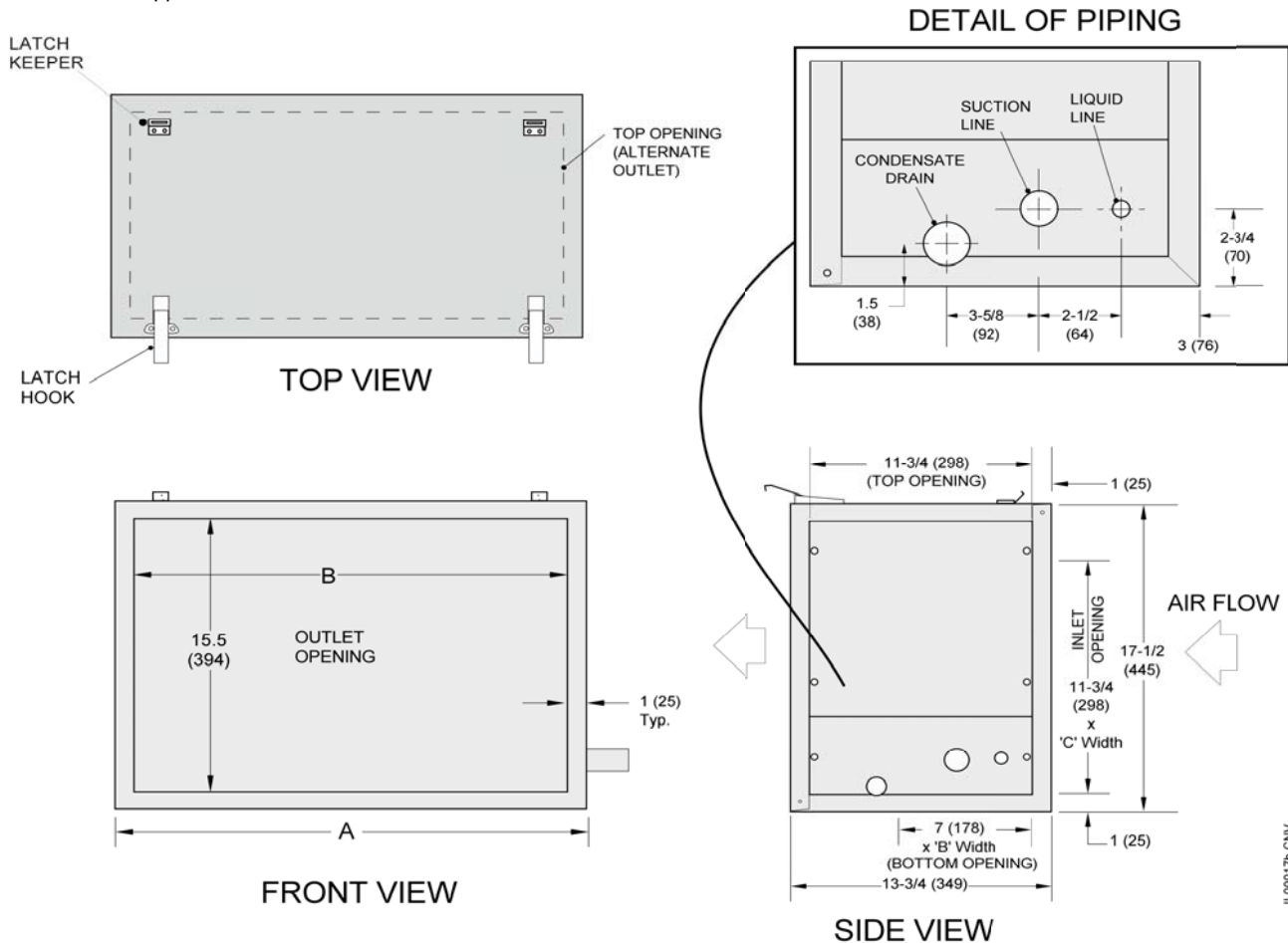

UNIT SHOWN FOR HORIZONTAL AIRFLOW ARRANGEMENT. USE ALTERNATE OPENINGS FOR VERTICAL ARRANGEMENT.
ALL DIMENSIONS IN INCHES (mm)

IL000176.CNV

MC4860x Specifications

Type of System		Cooling Only	Heat Pump
Model No.		MC4860C	MC4860H
Compatible Condenser Size, Ton (kW)		4-5 (14-17.6)	
Evaporator Coil	Net Face Area, ft ² (m ²)	7.44 (0.69)	
	Tube diameter, in. (mm)	3/8 (9.5)	
	Number of rows	3	4
	Fins per inch (m)	14 (551)	
	Suction line, in. (mm) OD	7/8 (22.2)	
	Liquid line, in. (mm) OD	3/8 (9.5)	
	Fin Type	sinewave	sinewave
	Number of Circuits	10	8
	Valve, R-22, Part No.	A00805-005	A00808-005
Valve, R-410A, Part No.	A00805-015	A00808-015	
Design Pressure, psig (kPa)		500 (3447)	
Condensate Connection, in. (mm) FPT		3/4 (19)	
Refrigerant		R-22, R-407C, R-410A*	
Coil Shipping Weight, lb. (kg)		88 (40)	
Factory Installed Expansion Device		TXV	TXV with Check Valve

* TXV shipped loose

DETAIL OF PIPING

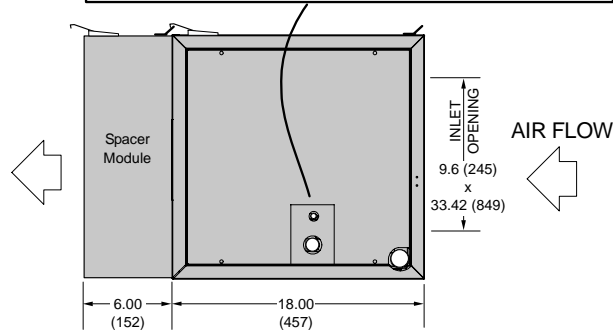
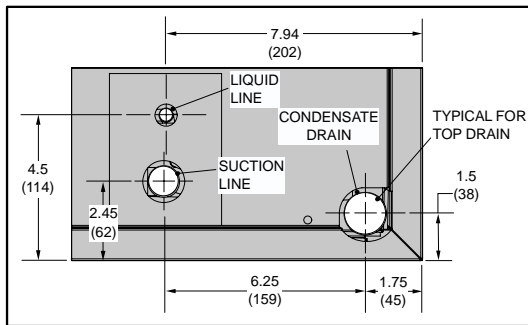

SIDE VIEW

Spacer Module is shipped with MC4860C/H Cooling Module

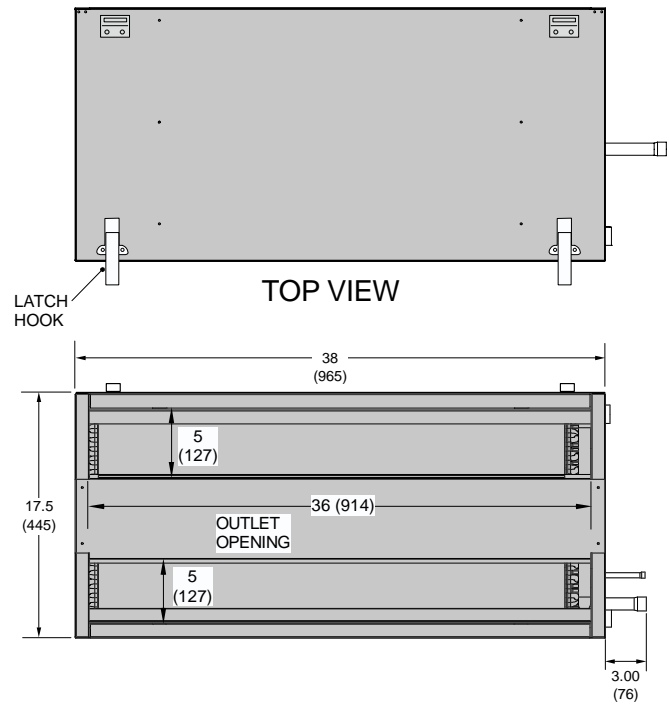

FRONT VIEW

UNIT SHOWN FOR HORIZONTAL AIRFLOW ARRANGEMENT. ALL DIMENSIONS IN INCHES (mm)

IL00283.07W

Cooling Capacity

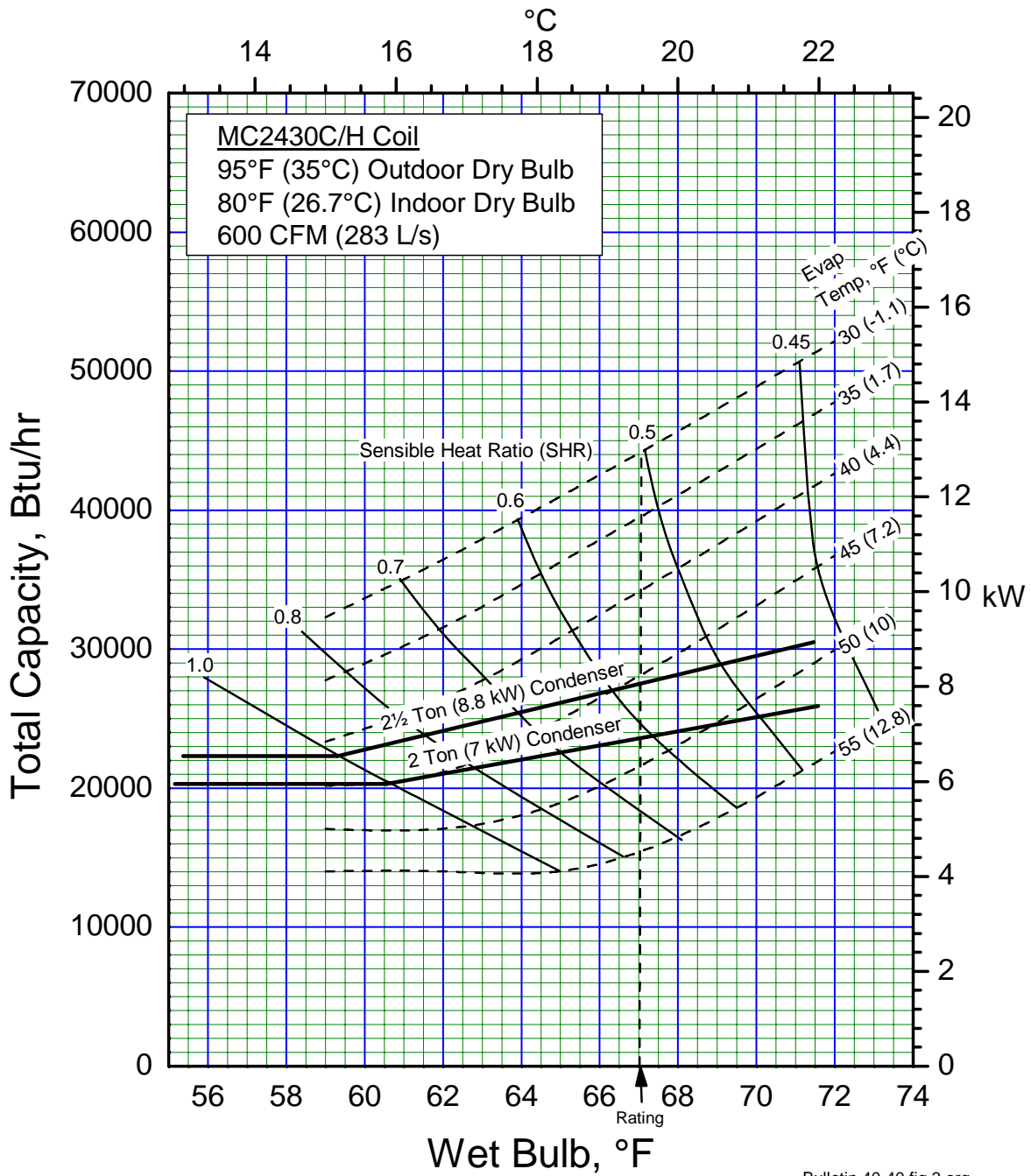

Bulletin 40-40 fig 3.org

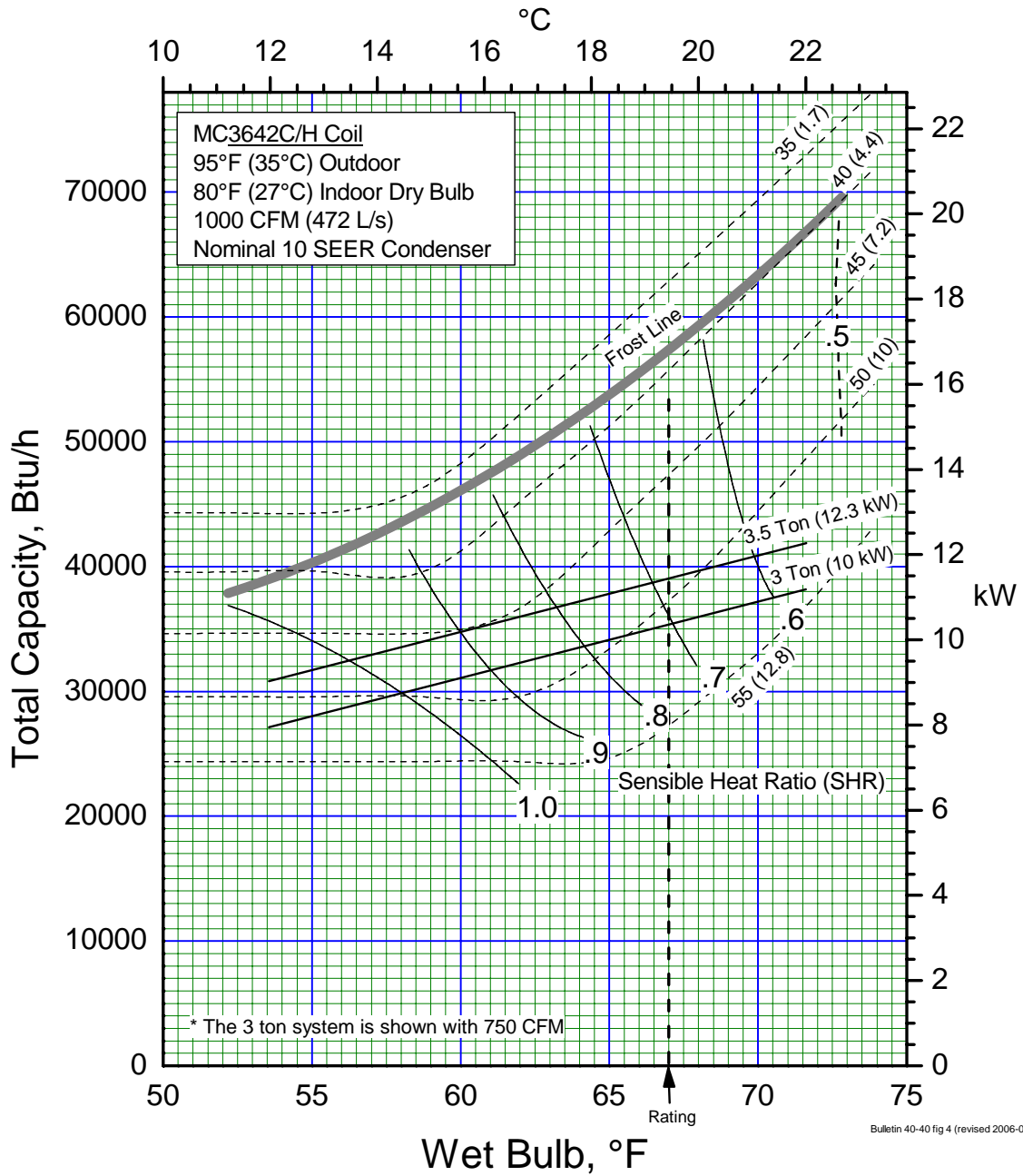

Typical Performance

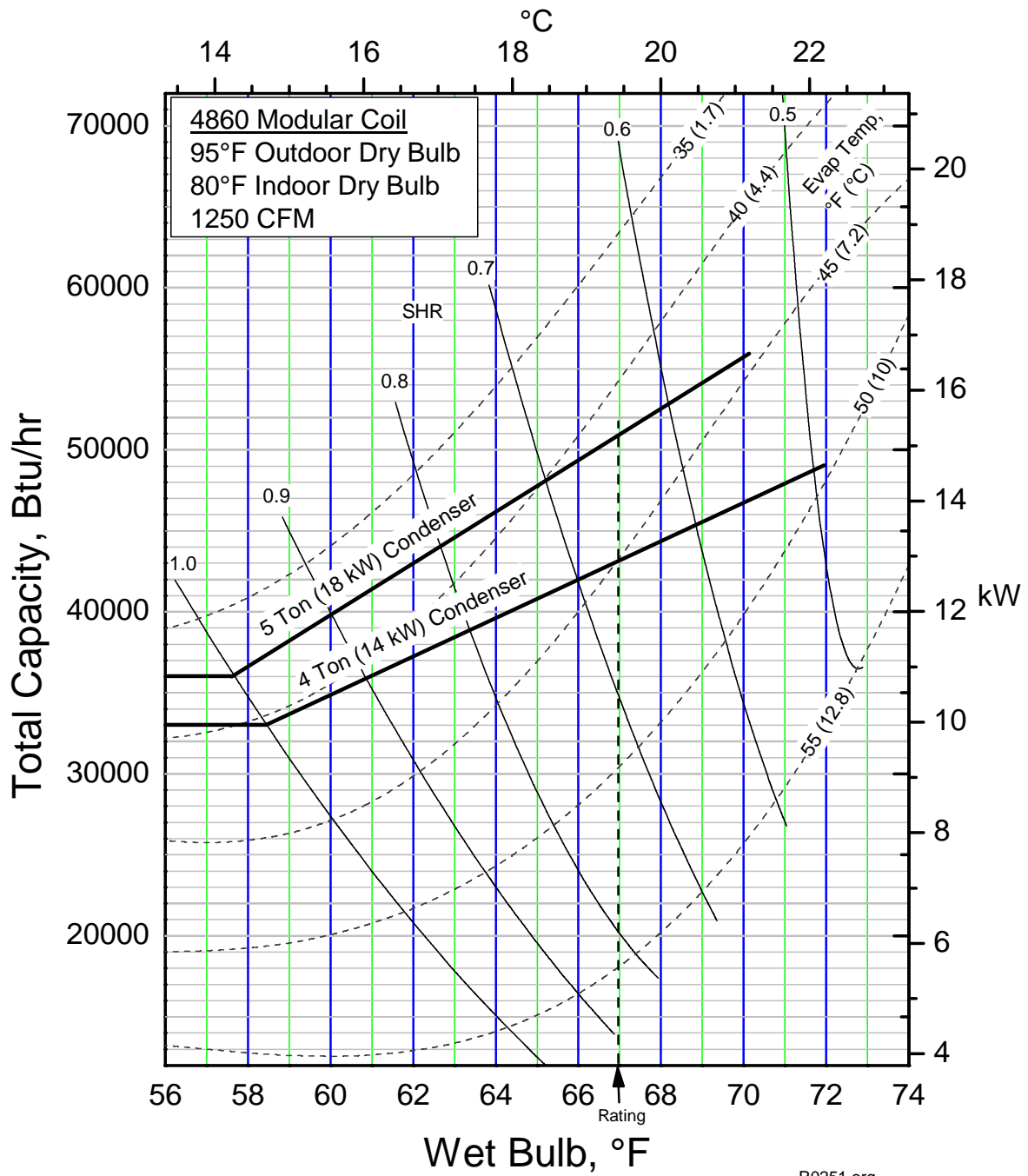

Heating Capacity

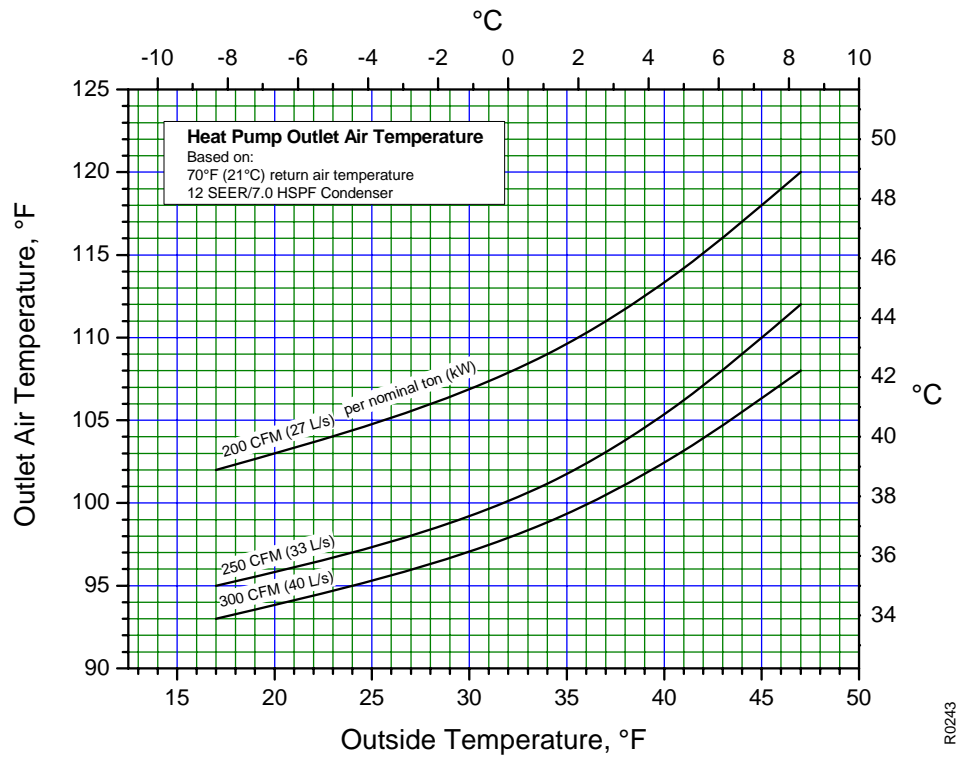

The Heat Pump System "That FEELS Warm"

