

Twist-Fit System Installation Instructions

APPLICATION

The Unico System® sound attenuator tubing is supplied in 12-ft (3.6-m) lengths for branch runs between 6ft and 12ft (1.8-m to 3.6-m). The 2-inch attenuator tubing comes with Twist-Fit System® (TFS) Couplings pre-installed for quick and easy installation. TFS Outlet Face Plates and TFS Take-offs are sold separately for easy customization of the duct run.

MATERIAL LIST

To complete a duct run from the plenum to the outlet, you will need at least one of each of the following kits:

- UPC-28T, TFS Take-offs for Metal Plenum
- UPC-25T, TFS Aluminum Supply Tubing (optional)
- UPC-26T, TFS Sound Attenuator Tubing
- UPC-56TB, TFS Outlet Face Plate (Plastic)
- UPC-57TB, TFS Wood Outlet Face Plate
- UPC-38T, TFS Coupling (only if duct is to be cut)

If connecting Twist-Fit System ductwork to a fiberglass plenum, use a UPC-22 or UPC-23B Spin-In Take-off instead of a UPC-28T.

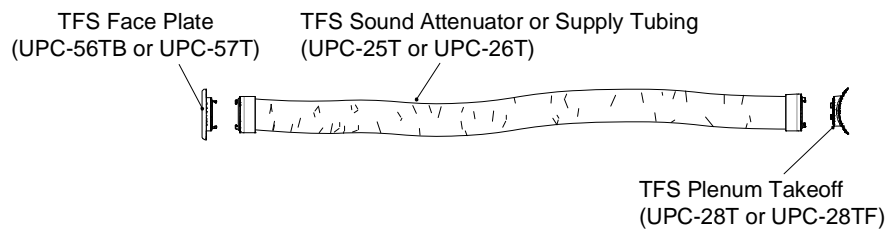

Method A (for 6 to 12 ft. runs)

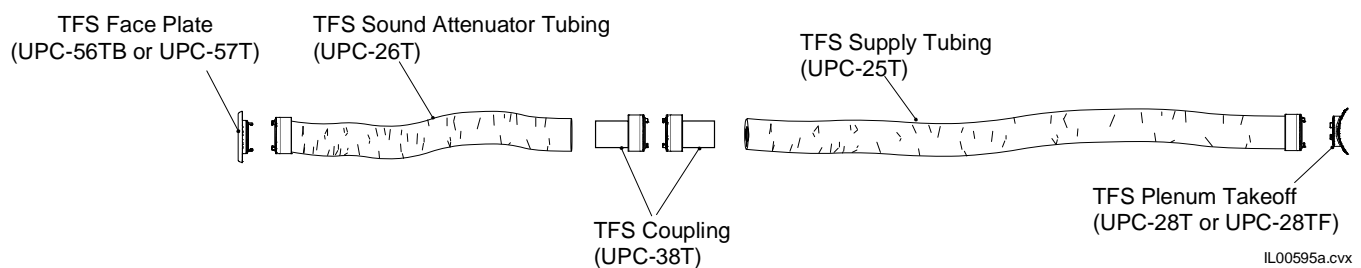

Method B (for 6 to 50 ft. runs)

Figure 1. Twist-Fit System Duct Connection methods (round or flat metal duct only)

CONFORMS TO UL STD 181
CERTIFIED TO
CAN/ULC STD S110-M86



INSTALLATION

First, determine the location of the outlet. The outlet may be placed in the ceiling, floor, or sidewall. The best place is the corner, 5 inches (127mm) from each wall. If that is not possible or practical, anywhere out of the traffic pattern is acceptable.

For floor outlets, be sure to install an outlet screen (UPC-88) to prevent objects from falling into the duct. The wood outlets (separate part number) come with screens built in.

For sidewall outlets, position the outlet well above head height. For optimum air circulation, position them 4 to 5-inches (102-127mm) below the ceiling but not more than 12 feet (4 m) above floor level.

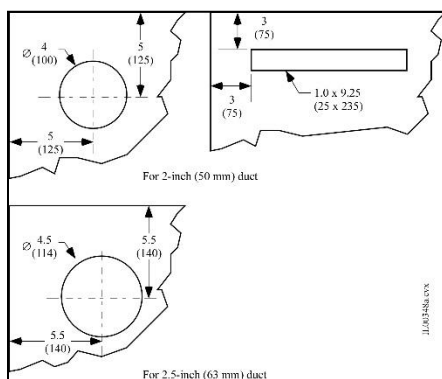

Figure 2. Location of corner outlets

After the location is determined a hole must be cut (if necessary) and the duct routed from the plenum to the outlet location.

For branch runs over 12 ft., use at least a 3-ft (1-m) sound attenuator coupled to the aluminum core supply tubing. The attenuator tubing may be cut to any length but not less than 3 ft. (1 m).

When installing the supply tubing follow these rules:

1. Use as few bends as possible.
2. If bends are necessary, provide a generous bend radius. The minimum radius is 6 inches (152mm).
3. Support the supply tubing every 4 ft. (1.2 m).
4. Be careful not to tear or puncture the supply tubing outer jacket.

When installing the duct system, use the following steps:

For New Construction Applications:

1. Install a plaster frame kit (UPC-86) where the outlet will be located.
2. Route the supply tubing so about 6 inches (152mm) protrudes through the hole in the plaster frame.
3. Remove the excess supply tubing at the plenum and connect to the plenum takeoff.

Note: If you have access to the plenum after terminator is secured, do this step last.

4. Push the duct up into the hole and install the drywall or paneling, cutting the appropriate 4 1/4 inches (114mm) hole for the frame.
5. Pull the duct out and attach the outlet to the coupling by aligning the tabs with the adjacent slots on the mating part (Figure 3). Twist the outlet until a click is heard.
6. Position the terminator in the hole and secure with toggles and screws.

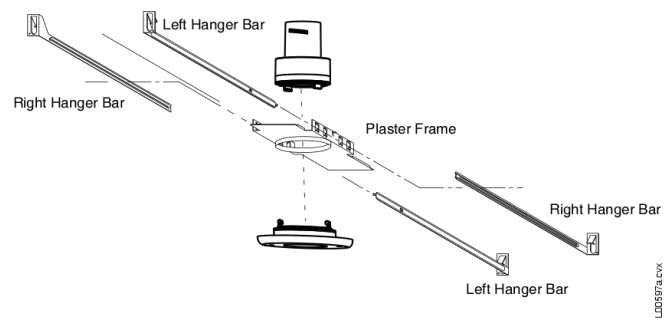

Figure 3. Twist-Fit System installation with Plaster Frame Kit

For Existing Structures:

1. Cut a 4 inch (102mm) hole in the plaster or drywall.
2. Then either route the supply duct through the hole to the plenum or from the plenum to the hole. If it is necessary to pull the duct through a floor joist, use either an electrician's "fish tape" or rope.
3. Remove any excess supply tubing at the plenum and connect to the plenum takeoff.
4. Allow about 6 inches (152mm) to protrude through the hole, removing any excess, and connect the outlet to the coupling by aligning the tabs with the adjacent slots on the mating part. Twist the outlet until a click is heard.

OUTLET FACE PLATE INSTALLATION

The UPC-25T and UPC-26T ducts come standard with Twist-Fit System Couplings pre-installed. One end will have a white coupling and the other will have a black coupling. This is a multi-purpose feature of the duct which allows you to match the color of the coupling to the color of the UPC-56TB or UPC-57T Face Plate that is purchased. For example, a white face plate (UPC-56TB) should be connected to a white coupling, and the colored (UPC-56TB-BLK/BRS/CHR) or wood face plates (UPC-57T) should be connected to the black coupling.

With the TFS Outlet Face Plate connected to the end of the sound attenuator, install the two toggles and screws in the mounting holes in the outlet faceplate. Feed or pull the duct through the 4-inch (102 mm) hole in the ceiling or floor until the two spring toggles begin to enter the hole. Force the upper portion of the toggles inward until they snap over the edge of the ceiling or floor. The toggles should be centered on a line parallel to the direction of the duct run from the outlet to the plenum takeoff. Loosen the screws if necessary, to assure toggles are sprung over the edge of the hole. Tighten the screws until the face plate is snug against the ceiling or floor.

CAUTION: TO PREVENT DAMAGE TO THE OUTLETS DO NOT OVERTIGHTEN THE TOGGLE SCREWS.

The supply outlet can be installed in the floor without toggles by drilling a hole 3-3/8-inch (86mm) in diameter instead of 4-inch (102 mm) and screw the cover plate directly to the floor by drilling two 5/64-inch (2mm) diameter holes on a 3-3/4-inch (95 mm) diameter bolt circle. The UPC-56TB supply outlet can be inserted into the 3-3/8-inch (86mm) hole and used as a template for the two screw holes. When installing the screws be careful that they do not break into the 3-3/8-inch (86mm) hole; drill and install at a very slight angle away from the 3-3/8-inch hole if necessary (Figure 4).

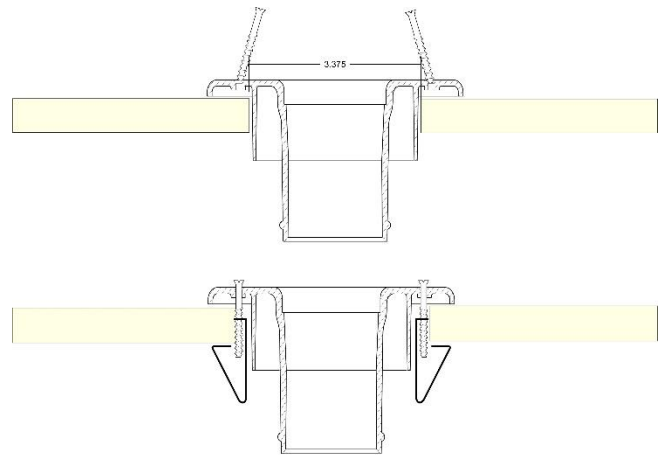

Figure 4. Supply outlet installed in floor without toggles (top) and with toggles and screws (bottom)

If installing an outlet in a wall, floor, or ceiling thicker than 1.5-inches (37mm), the outlet toggles will need to be trimmed. Trim the leg of the outlet toggle that normally contacts the back side of the wall at a 30 to 60-degree angle, giving it a sharp point (Figure 5). This will allow the toggle to dig into the wall. Install the outlet according to the instructions in the previous paragraph.

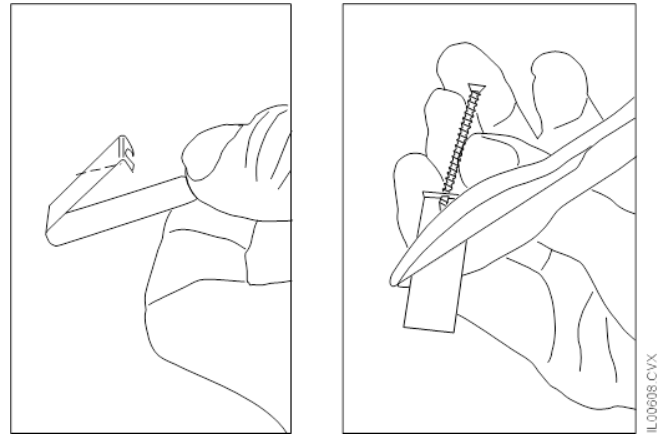

Figure 5a. Modification of outlet toggles for walls thicker than 1.5-inches.

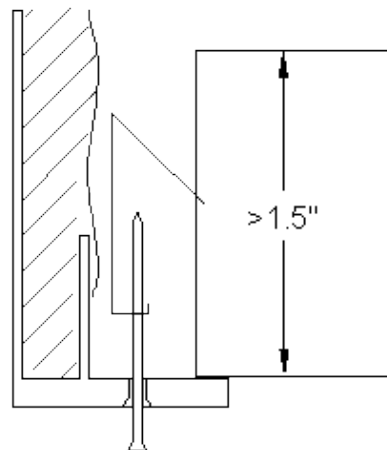
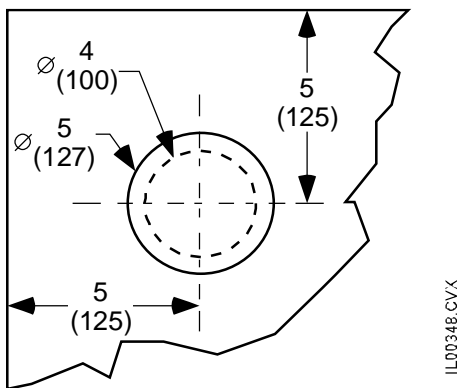

Figure 5b. Modified toggle secured into thick wall material.

UPC-57T – Wood Outlets

For Flush-Mount TFS Wood Faceplates (UPC-57T-F):

1. Make sure the wood faceplate is the same thickness as the finished floor you are installing it in (the Flush-Mount Faceplates are 3/4in thick). If not, you will need to plane or sand the faceplate to the same thickness before installing.
2. Determine location of outlet in ceiling, wall, or floor and cut a 5in (127mm) hole. **CAUTION – if installing in floor, be sure not to cut through subfloor.**
3. Cut a 4 inch (102mm) hole through the subfloor in the 5in (127mm) hole cut in step 1.



4. Pull Sound Attenuator Duct (UPC-26T) through opening about 6 in (91 cm)

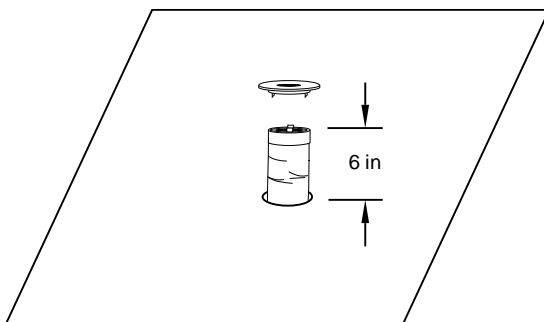

5. Connect the Twist-Fit System Wood Face Plate to the black duct coupling by aligning the tabs with the slots and turning clockwise to lock into place.

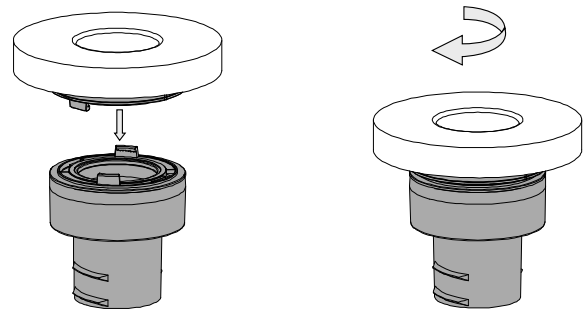

6. Using adhesive (clear caulk or light construction adhesive), secure the wood face plate to the subfloor or wall.

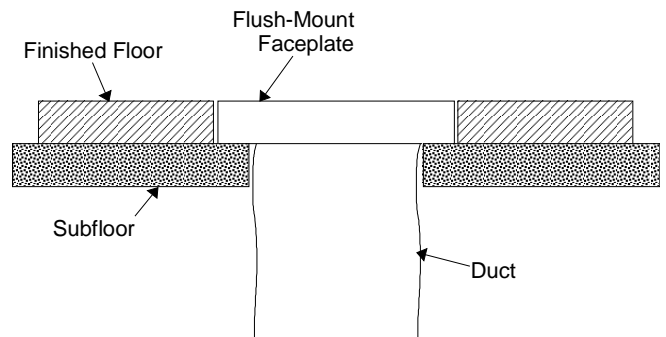

For Surface-Mount TFS Wood Faceplates (UPT-57T):

1. Determine location of outlet in ceiling, wall, or floor and cut a 3-3/8 in (86 mm) diameter hole.

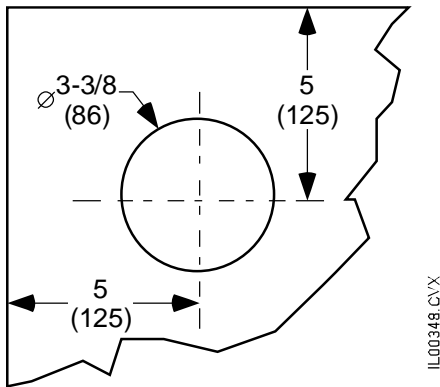

2. Pull Sound Attenuator Duct (UPC-26T) through opening about 6 in (91 cm)

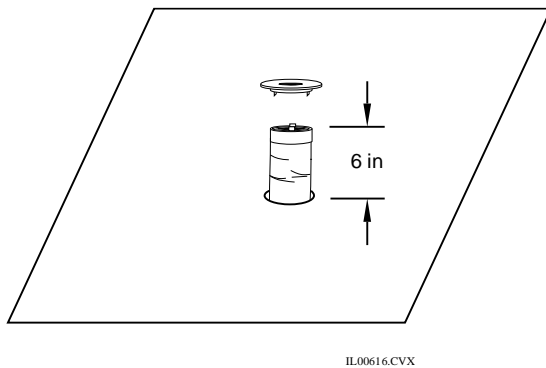

3. Connect the Twist-Fit System Wood Face Plate to the black duct coupling by aligning the tabs with the slots and turning clockwise to lock into place.

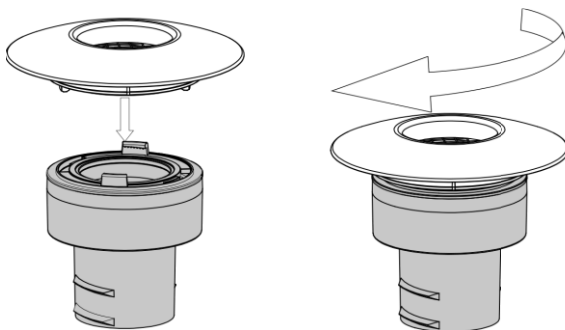

4. Feed the duct through the hole and using adhesive (clear caulk or light construction adhesive), secure the wood face plate to the mounting surface.

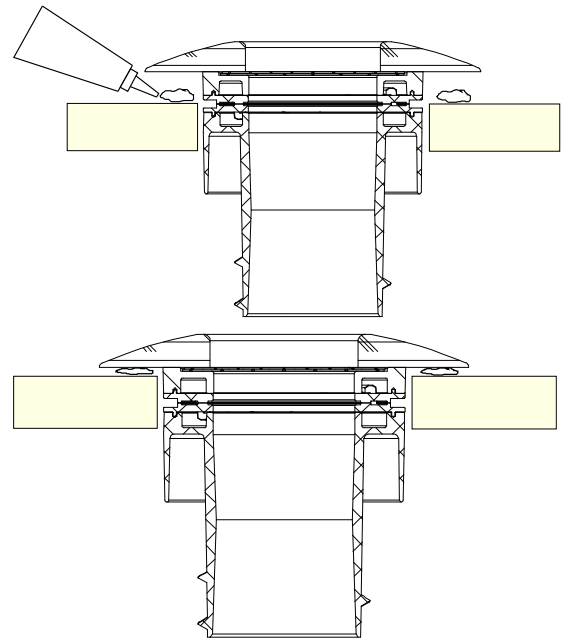

5. Step 5: As an alternative, pre-drill holes and secure the wood face plate to the mounting surface using wood screws.

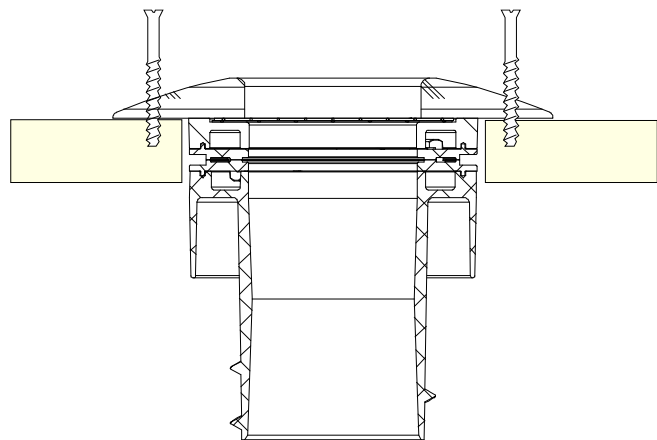
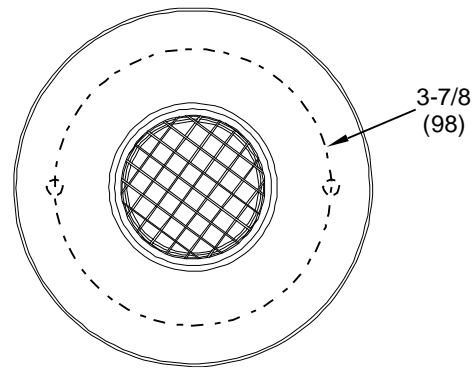

PLENUM TAKEOFF INSTALLATION

Position the plenum takeoff so that the least amount of stress is applied to the connection and the duct is as straight as possible. For example, if the branch ducts need to run horizontally, then locate the takeoff between the 2 and 4 o'clock position.

The first step is to attach the plenum takeoff to the plenum. There are two styles of takeoffs. Use the one that is appropriate for the type of plenum used.

For plenum made from 1 inch (2.5 cm) fiberglass duct board or 20 mm rigid phenolic foam board:

1. Use a UPC-55 hole cutter ("cookie" cutter) to make a 2 inch (51mm) hole in the plenum.
2. Cut a ½ inch (12.7mm) slit in the plenum jacket.
3. Bend the starting edge of the spin-in (UPC-23B) takeoff thread flange as shown in Fig. 6.

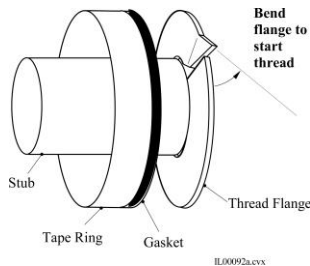

Figure 6. Spin-in Takeoff (for 1" Fiberglass Duct)

4. Then push and twist the spin-in into the hole as if threading a screw. Spin the takeoff a full 360° around. Inspect the inside of the takeoff to be sure no insulation from the plenum is projecting into the air stream. Continue to spin the takeoff until no excess insulation can be seen down inside the stub of the takeoff. Be sure that the bottom flange is fully engaged on the inside of the plenum. Figure 7 shows a spin-in fully threaded in to the duct.

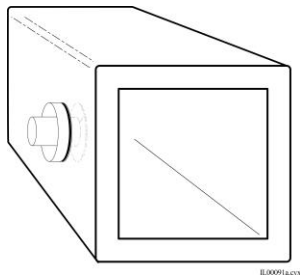

Figure 7. Fiberglass Plenum Takeoff Location

For plenum made of thin wall metal (sheet metal):

1. Connect plenum take-offs before insulating plenum if possible. If not, cut a cross (+) shape in the insulation and peel back the corners to expose the bare metal duct (Figure 8).

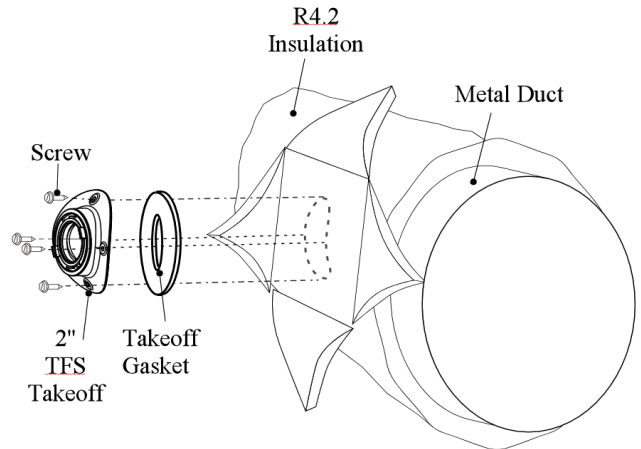

Figure 5. Metal Plenum Takeoff Installation

2. Attach insulated Twist-Fit System Take-off directly to plenum using four ¾"-1" sheet metal screws.
3. Use a hole saw (with extension if necessary) to cut through the duct. For 2" duct use 1-7/8" (47.6mm) diameter hole saw
4. Visually inspect the hole for any excess metal.
5. Align the tabs on the TFS Coupling with the slots on the Take-off. Twist the coupling-duct assembly until a click is heard.
6. Fold the flaps of the insulation back over the take-off and secure in place with UL-181 tape.