

For: File Resubmit Approval Other _____

M1218CL1-H 1.5-ton SDHV Hot Water Coil Heating Module

Job Name:	Location:
Date:	Tag #:
Architect:	Engineer:
Mechanical:	Distributor:
Rep:	
(Company)	(Project Manager)



M1218CL1-H

Features

- Modular construction
- Multiple configurations
- Enhanced Aluminum fins
- Copper tubes
- Fully lined with closed cell insulation

Matching Modules

M1218BL1-EC1
M1218BL1-EC2
M1218BL1-ST2
M1218CL1-C
M1218CL1-E

Indoor Unit Size

1218

Operating Range:

Nominal Capacity	1.5-ton (5 kW)*
Airflow Range	100 to 500 CFM (170 to-850 m ³ /h)
Capacity Range	9,900 – 33,200 BTU/hr (2.9 -9.6 kW)
Water Flow Rate Range	2 – 6 GPM (0.13 – 0.38 L/s)
Entering Water Temperature	120 – 160°F 48.9 – 71.1°C

* Nominal capacity at 400 CFM, 120F entering water temp., 6 GPM water flow rate, 70F entering air temp.

General Data:

Net coil face area	1.00 ft ² (0.093 m ²)
Tube diameter	3/8 in. (9.53 mm)
Number of rows	4
Fin density	10/in. (394/m)
Water Connection Size, ODF Sweat	5/8 in. (15.87mm)
Design pressure	150 psig (1034 kPa)
Coil Water Volume	0.3 gal (1.2 L)
Shipping Weight (Cabinet Only)	17.4 lbs. (8.0 kg)
Shipping Weight (Coil Only)	8.5 lbs. (3.85 kg)
Cabinet Dimensions (H x W x D)	16 x 20 x 6 in. (406 x 508 x 152 mm)
Coil Dimensions (H x W x D)	15.9 x 19 x 4 in. (403 x 483 x 101 mm)

Optional Accessories:

- Return adapter (UPC-104-1218)

Notes:

1. All wiring and piping must comply with applicable local and national code.
2. Refer to installation manual for more information.

Model Number Key (available models):

M	1218	C	L	1	-	X	1
Model Series	Nominal Capacity	Module Type	Configuration	Revision		Style	Options
M = Modular	1218 = 12000 to 18000 Btu/hr	C = Coil	L = Left R = Right			X = Cabinet Only, No Coil H = Hot Water Coil	1 = Paint White

M1218CL1-H

Job Name:

Location:

Date:

Tag #:

HOT WATER COIL MODULE DIMENSIONS (LEFT HAND)

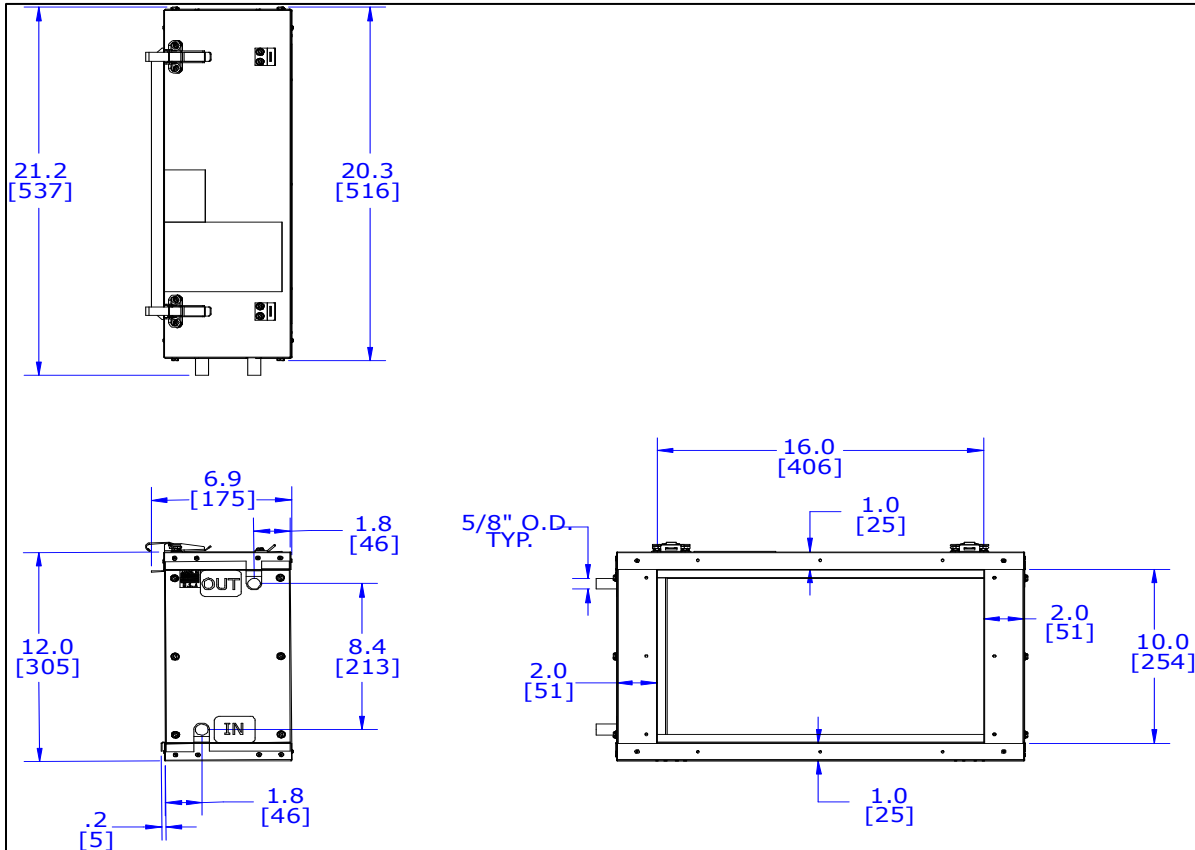

* All dimensions in inches [mm]. Contact Unico for dimensions of assembled modules or for right hand dimensions

Installation Clearances

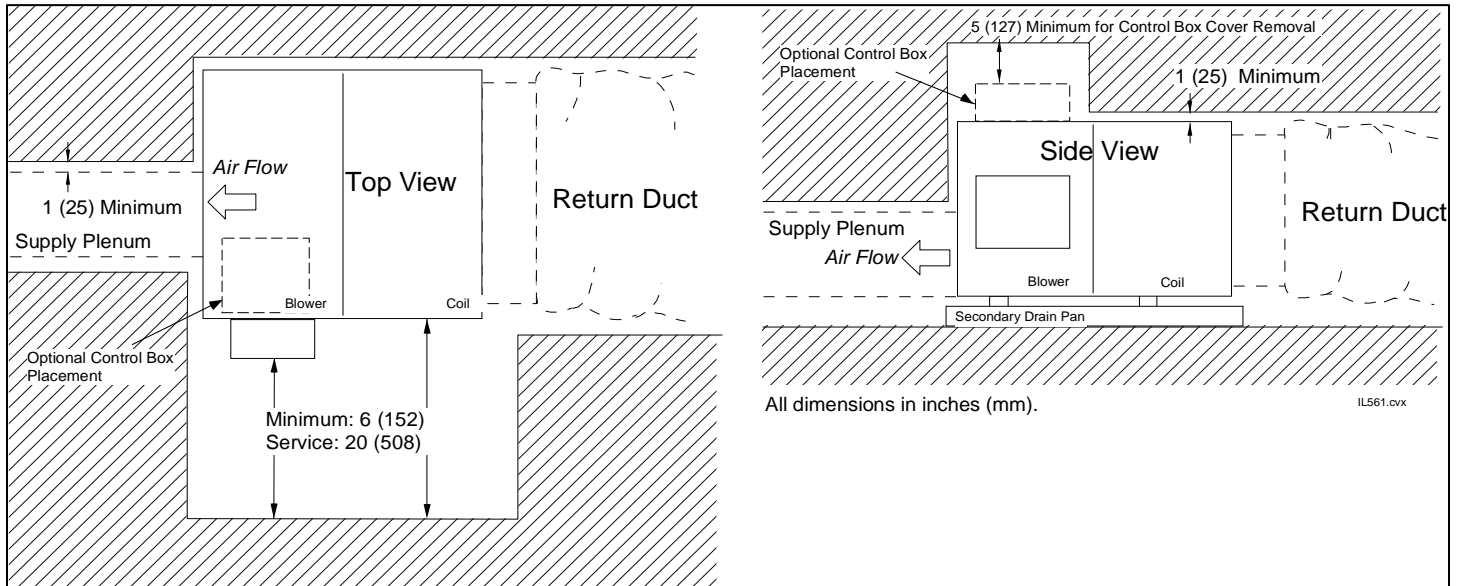

Unico, Inc.
<http://tech.unicosystem.com>
 314-481-9000
 800-527-0896
 sales@unicosystem.com

